

START-UP

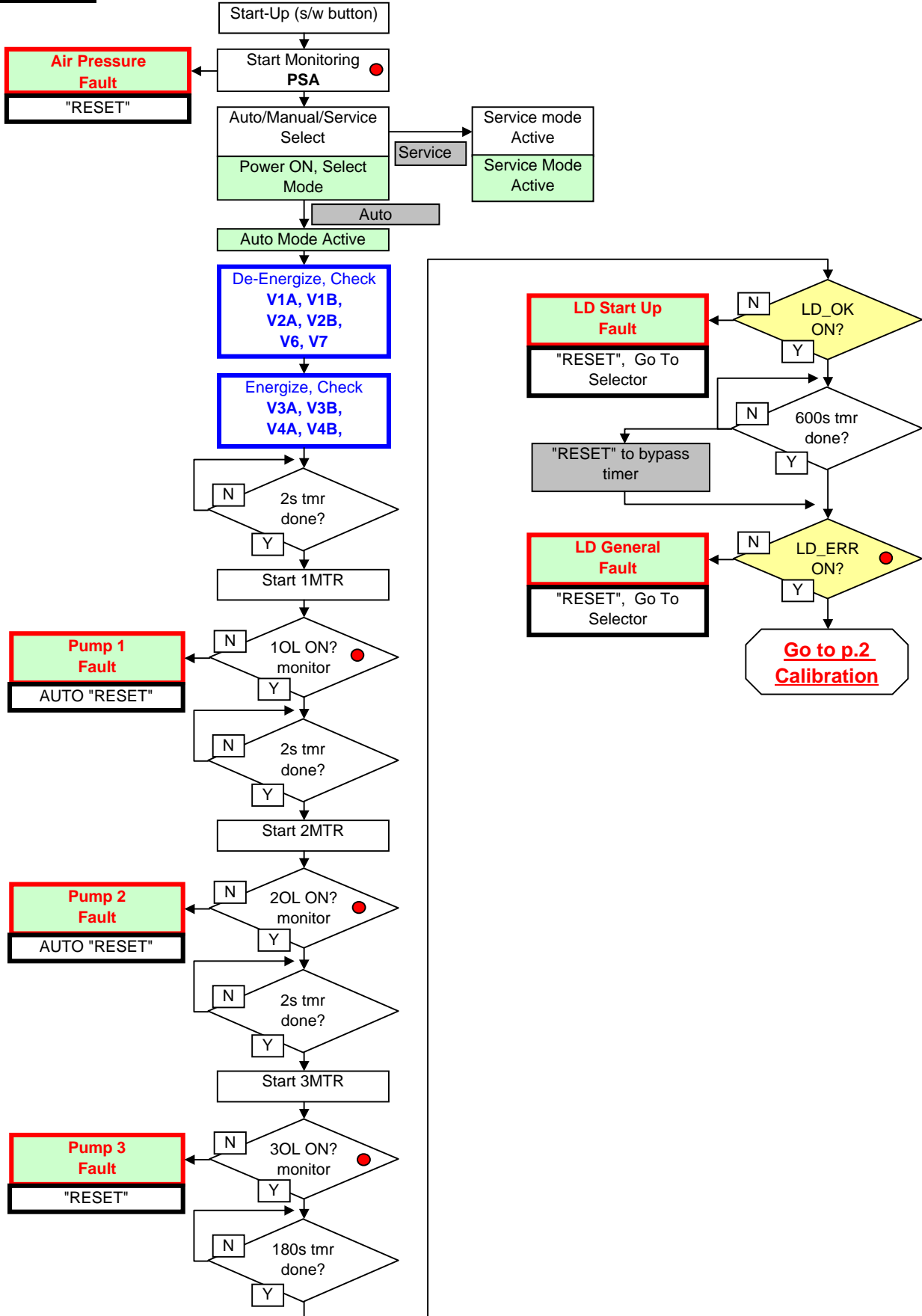

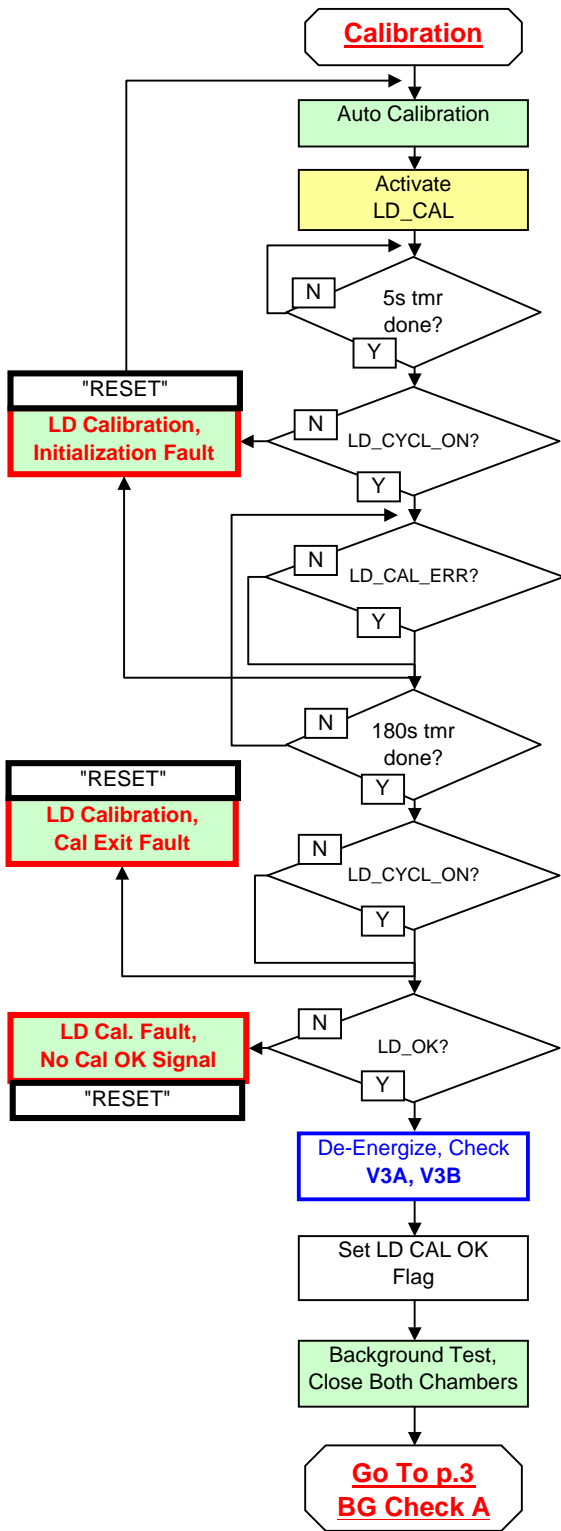

VALVES Subroutine

V1A

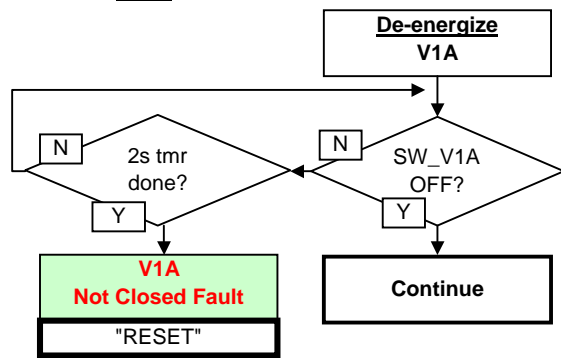
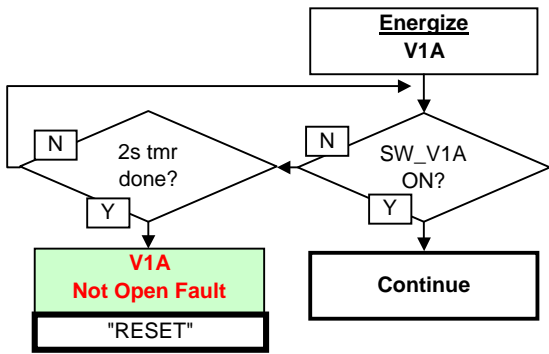

V1B

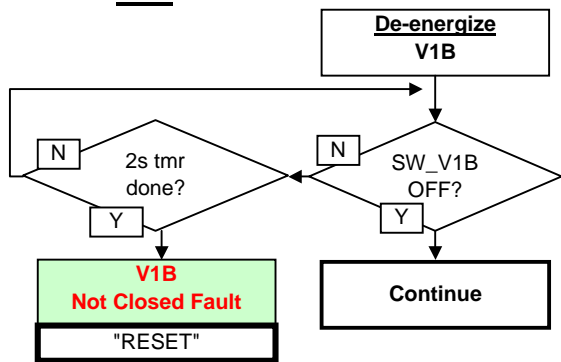
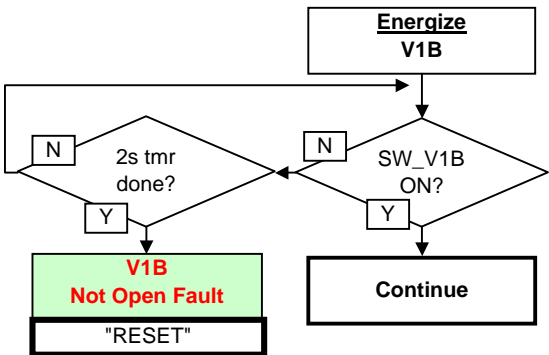

V2A

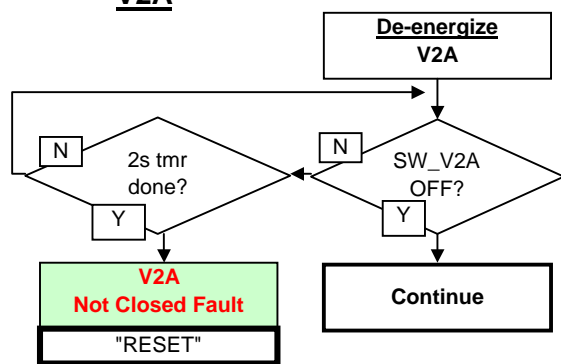
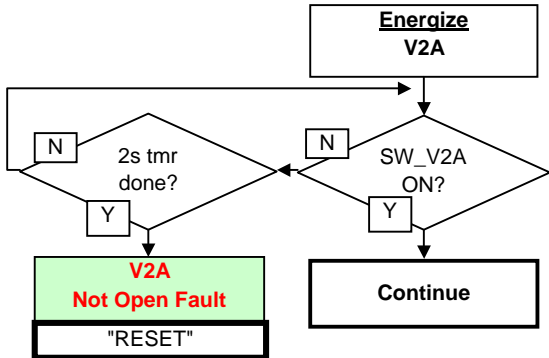

V2B

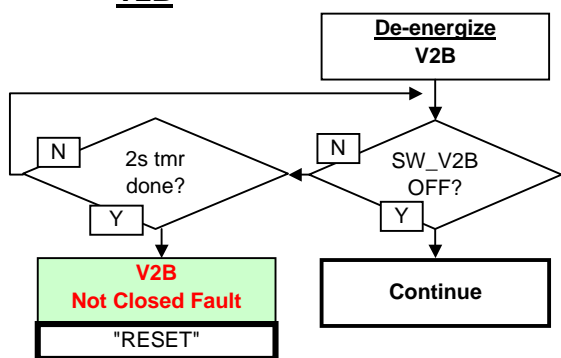
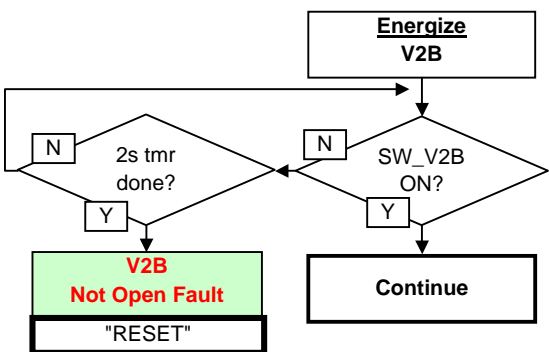

V3A

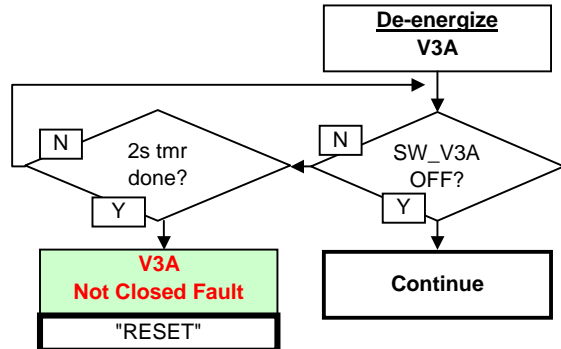
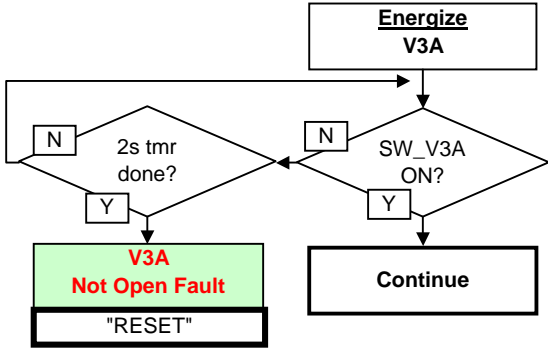

V3B

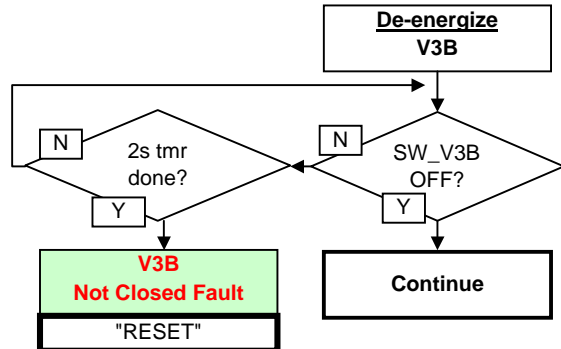
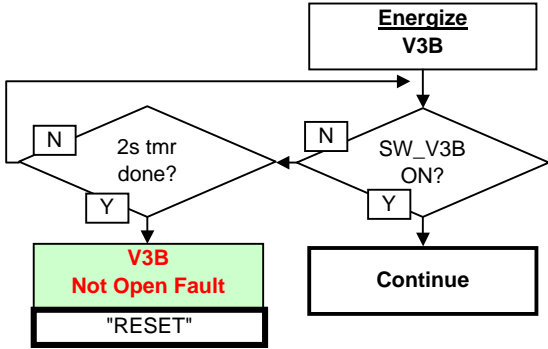

V4A

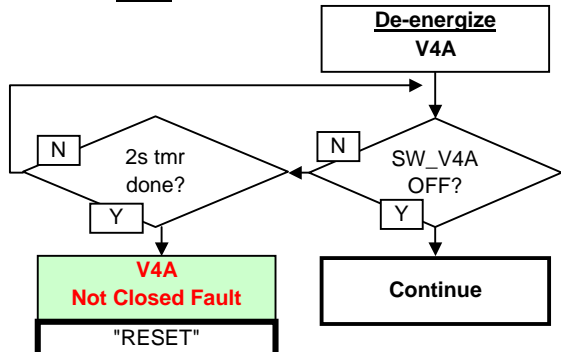
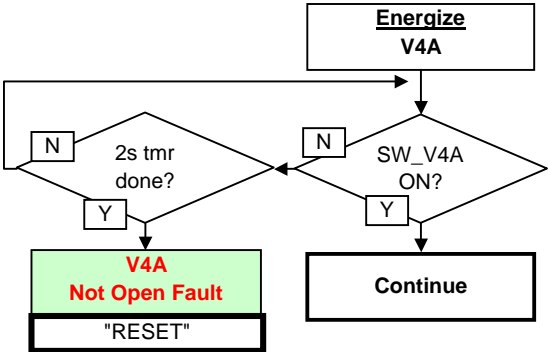

V4B

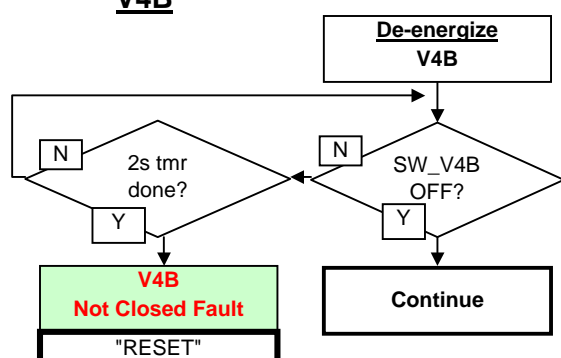
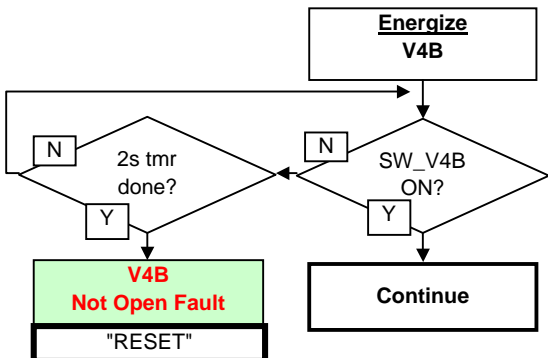

VALVES Subroutine (Cont.)

V6

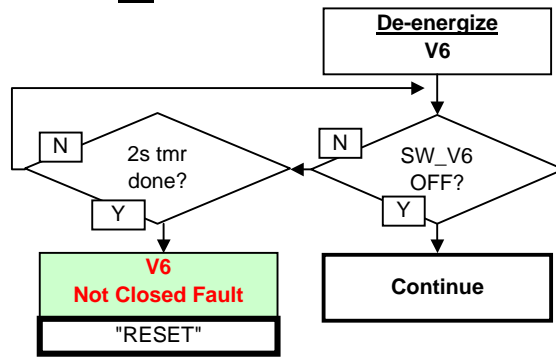
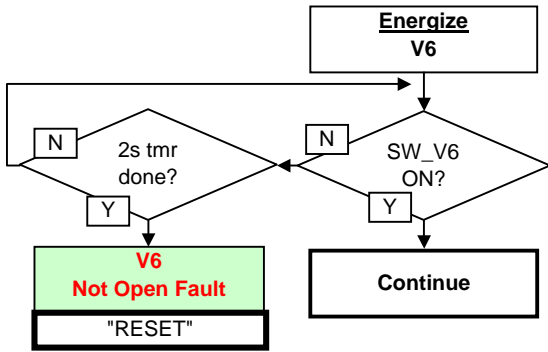

V7

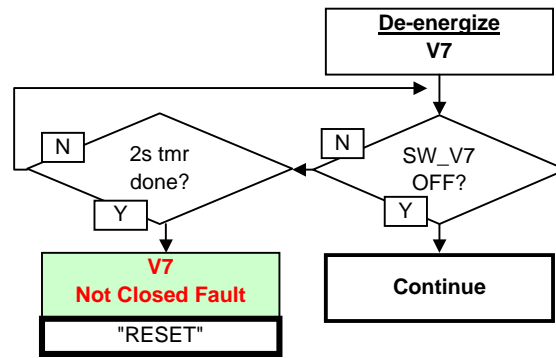
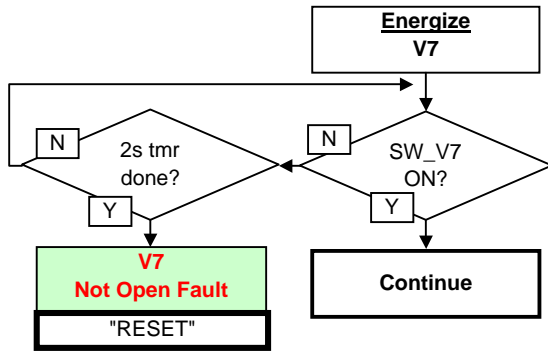

BACKGROUND CHECK A

Large Leak A Subroutine

