

# How a Brushless Motor Operates

By John Mazurkiewicz

Baldor Electric

You understand AC motor operation, even a DC motor is relatively easy to figure out. However brushless motor operation is still “medieval science”. The following will lead you out of the dark ages and into today’s modern world – the use of brushless technology.

## Theory is all the same

Brushless motor rotation relies on the identical theory as for AC and DC motors. That is, two magnetic fields interact, which result in movement. In the case of AC motors, the stator winding sets up one magnetic field while inducing the second interacting field onto the squirrel cage rotor. With DC motors, the permanent magnet stator sets up the first magnetic field, and the rotor windings produce the second field.

These two magnetic fields interacting, results in rotation. In the DC motor, the two fields try to align. However the commutator continually switches power from winding to winding. Thus, maintaining the two magnetic fields at a 90 degree relationship. If they did indeed align, motor rotation would not occur.

Compared to DC motors, brushless technology has been termed an “inside out” design. That is, the permanent magnets are on the rotor, and the stator consists of windings. The design still consists of two magnetic fields interacting.

## Brushless Servomotor

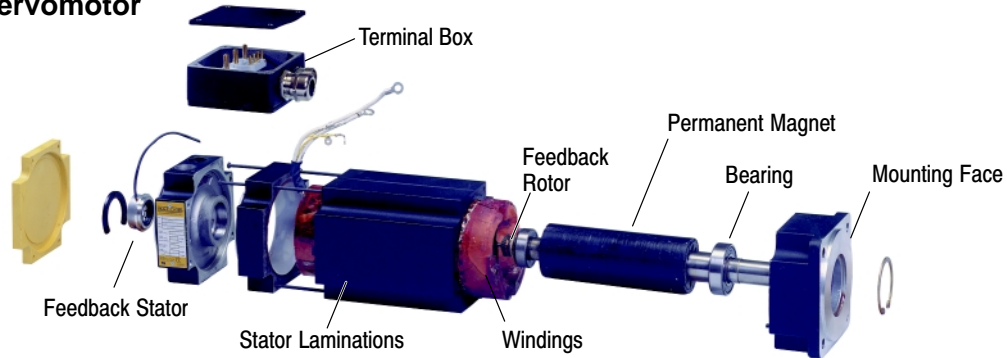

## Brushless rotation

To begin to understand how brushless motor operate, refer to Figure 1. Power is applied to winding “R” and current flow sets up a ‘north’ pole which the permanent magnet will react to, and begin movement. This movement will cease when the ‘south’ pole of the magnet aligns it.

Figure 1 – Basic brushless motor

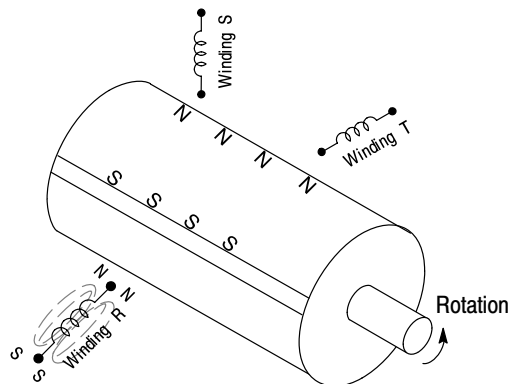

However, if, at the appropriate time, current is shut off in winding “R”, and turned on in winding “S”, then the rotor continues to move. Again at the appropriate time, shut off “S” and turned on “T”. By continuation of this timing sequence, complete rotation occurs. What is occurring, is that the field set up by the stator is being switched, and the rotor tries to catch up to it.

In this example, the explanation was simplified by exciting only one winding at a time. In reality, the stator consists of a three phase Y-connected winding, and two or three windings are actually energized.. This makes efficient use of windings and development of higher motor torques.

### Electronic commutation

Current is being switched from winding to winding (which is an identical function of the mechanical commutator in a DC motor) and this action of switching current in the brushless motor has been termed “electronic commutation”.

The next question arises is, “how does the motor know when to switch current, or commute?” Actually the motor does none of the “electronic commutation”, it is accomplished by the control, which is running the motor.

The brushless motor consists of a stator assembly with a three phase Y-connected winding. A rotor assembly consists of a four-pole permanent magnet, and a smaller “sensor” magnet. This sensor magnet will turn Hall devices “on” and “off”. The Hall devices thus provide shaft position and provide information about location of the rotor magnet. This is shown in Figure 2.

**Figure 2 – Brushless motor interfaces**

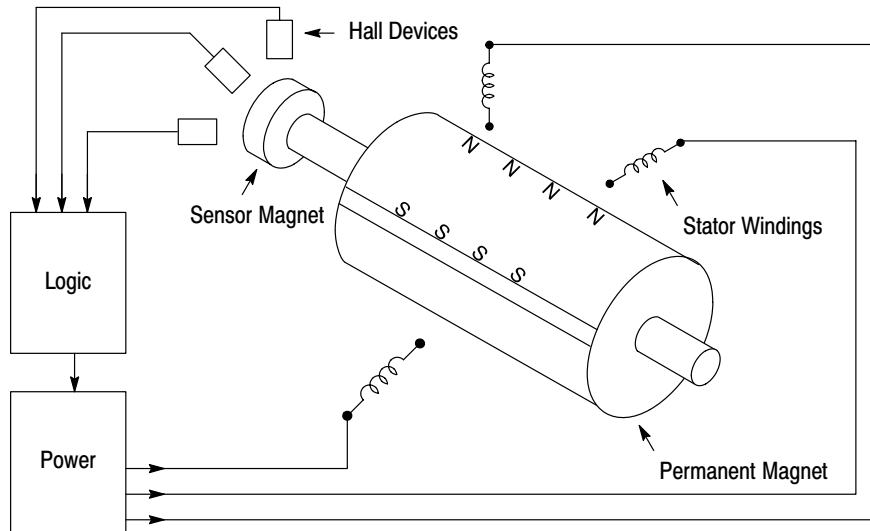

The control consists of logic circuitry and a power stage to drive the motor. The control's logic circuitry is designed to switch current at the optimum timing point. It receives information about the shaft/magnet location (signals from the Hall devices), and outputs a signal, to turn on a specific power device, to apply power from the power supply (not shown) to specific windings of the brushless motor.

## Depends on timing

Sequencing of operation is explained by the timing diagram of Figure 3. The Hall devices 1, 2, and 3 turned “on” and “off” as they rotate thru one mechanical revolution. The “on” and “off” signals correspond to a binary code output. This turns on specific power stage devices, resulting in current flow. For example, a binary code output of “5” turns on power stage devices #3 and #2, and current will flow thru motor windings.

**Figure 3 – Brushless timing diagram**

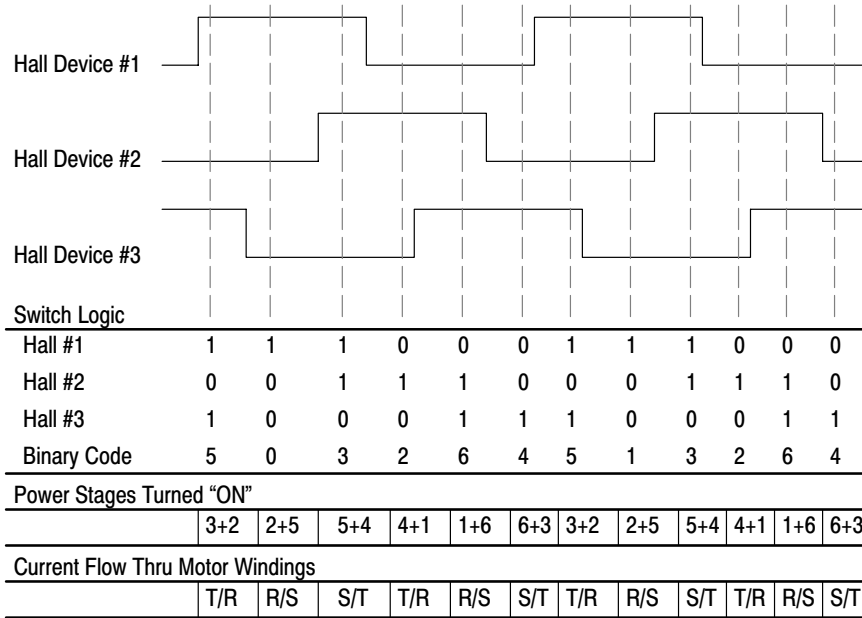

See Figure 4

The rotor moves (also the Hall devices), causing the signal into the logic circuitry to change. When this occurs, the binary decoder changes its output signal to a “1”. This turns on power stage devices #2 and #5, and current continues to flow.

Figure 4 shows what is occurring. Once again from the beginning, the binary circuitry looks at the signals from the Hall devices and outputs the specific binary code “5”. This turns on power devices #3 and #2. Follow the current flow from the power supply, through power device #3, through the stator winding “T” and winding “IC”, and finally through power device #2 to ground.

**Figure 4 – Brushless motor interfaces**

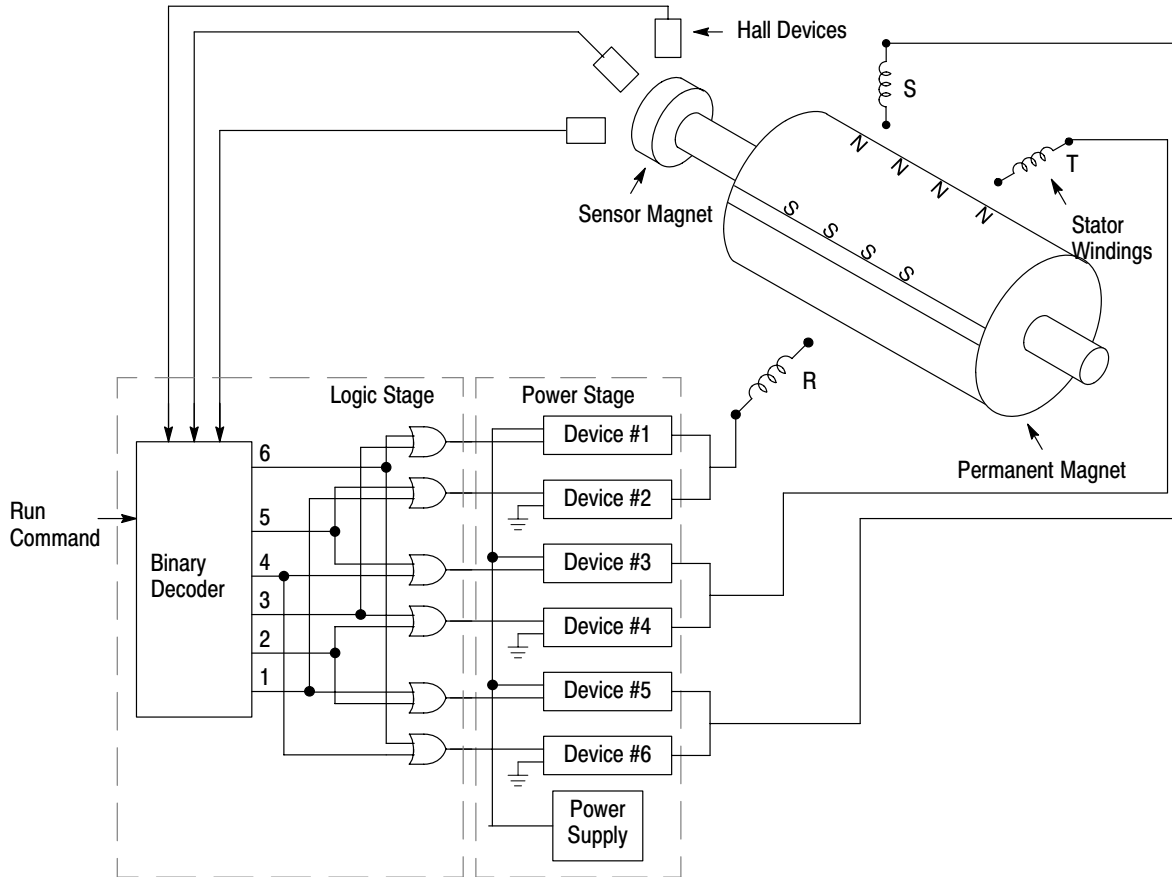

As the rotor turns and the Hall device changes their signals, the binary decoder output changes to a “1”. Power devices #2 and #5 are turned on. Current flow is from the power supply, through power device #2, through stator winding “IC” and “S”, through power device #5 to ground. This

sequencing of events continues, and the motor continues to rotate until the “run” command is removed.

Keep in mind, that as power is applied to motor windings, that pulse width modulation (PWM) power design techniques are employed. This aids the design by keeping temperature of the devices down, allowing for use of smaller components.

The method described above, with Hall devices simplifies the explanation. In industry today, there are other feedback devices which are also used with the application of brushless motors. Many manufacturers use either resolver or encoder feedback with their control design, however the “electronic commutation” concept remains the same: feedback from a device informs the control when to “electronically” switch power, resulting in brushless motor operation.